



### Product Description:

- Fixed output constant voltage built-in control gear for LED in 12/24 V
- Input voltage range 220 – 240 VAC
- Max. output power 60W
- Connection cable with stripped cable end (length approx. 300 mm ± 10 mm)
- Polarity identifiers, secondary + red / - black
- IP66 metal casing
- Nominal life-time up to 30,000 h (at Ta 50 °C with a failure rate max. 0.2 % per 1,000 h)
- 3-year guarantee
- Complies with CLASS C from 70 to 100 % load according to EN 61000-3-2



### Properties:

- Low power loss
- Over-temperature, Overload, and Short-circuit protection
- SELV
- Type of protection: IP66
- Metal casing



### ORDERING GUIDE

Type 12V	LC 60W 12V IP66 slim SNC
Type 24V	LC 60W 24V IP66 slim SNC
Article Number 12V	28001026
Article Number 24V	28001028
Packaging Carton 12V	10 pc(s).
Packaging Carton 24V	10 pc(s).
Packaging Pallet 12V	560 pc(s).
Packaging Pallet 24V	560 pc(s).
Weight per pc. 12V	0.7 kg
Weight per pc. 24V	0.7 kg

### SPECIFIC TECHNICAL DATA

Type 12V	LC 60W 12V IP66 slim SNC
Type 24V	LC 60W 24V IP66 slim SNC
Max. Casing Temp T <sub>c</sub> (both)	70° C
Output Voltage 12V	12 V
Output Voltage 24V	24 V
Max. Input Power 12V	80 W
Max. Input Power 24V	75 W
Output Current Range 12V	0.4 - 5.0 A
Output Current Range 24V	0.2 - 2.5 A
Max. Output Voltage <sup>1</sup> 12V	13.2 V
Max. Output Voltage <sup>1</sup> 24V	25.2 V

<sup>1</sup> At failure mode (230 V, 50 Hz)

### TECHNICAL DATA

Rated Supply Voltage	220 - 240 V
Input Voltage, AC	198 - 264 V
Rated Current (at 230 V, 50 Hz)	0.33 A
Mains Frequency	50 / 60 Hz
Efficiency 12V (at 230 V, 50 Hz, full load)	> 83%
Efficiency 24V (at 230 V, 50 Hz, full load)	> 85%
λ (at 230 V, 50 Hz, full load)	> 0.93
Output Voltage Tolerance 12V	0/ +10 %
Output Voltage Tolerance 24V	-5 / +5 %
Output Power	60 W
Output Power Range	5 - 60 W
Turn On Time (Output)	≤ 0.5 s
Turn Off Time (Output)	≤ 1 s
Hold on Time at Power Failure (Output)	10 ms
Ambient Temperature T <sub>a</sub>	-25 ... +50° C
Ambient Temperature T <sub>a</sub> (at life-time 50,000 h)	-25 ... +50° C
Storage Temperature T <sub>s</sub>	-25 ... +85° C
Dimensions (L x W x H)	230.5 x 42.5 x 32 mm
Hole Spacing 12V	220 x 17.5 mm



**DIMENSION DRAWINGS**

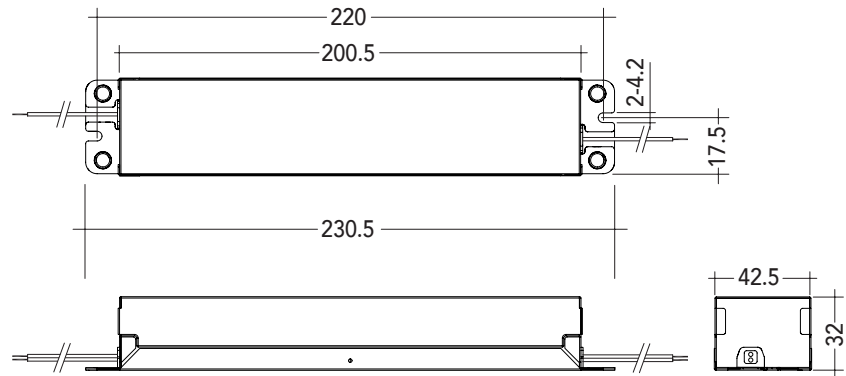

**EXPECTED LIFE-TIME**

Type	Output Voltage	Ta	40° C	50° C
LC 60W 12V IP66 slim SNC	12 V	Tc	60° C	70° C
		Life-time	> 100,000 h	> 30,000 h
		Tc	60° C	70° C
LC 60W 24V IP66 slim SNC	24 V	Tc	60° C	70° C
		Life-time	> 100,000 h	> 30,000 h
		Tc	60° C	70° C

**HARMONIC DISTORTION IN THE MAINS SUPPLY (AT 230 V / 50 HZ AND FULL LOAD IN %)**

Type	THD	3	5	7	9	11
LC 60W 12V IP66 slim SNC	7	6	3	1	2	3
LC 60W 24V IP66 slim SNC	9	7	3	1	2	3

**MAXIMUM LOADING OF AUTOMATIC CIRCUIT BREAKERS**

Automatic Circuit Breaker Type	C10	C13	C16	C20	B10	B13	B16	B20	Inrush Current
Installation Ø	1.5 mm <sup>2</sup>	1.5 mm <sup>2</sup>	1.5 mm <sup>2</sup>	2.5 mm <sup>2</sup>	1.5 mm <sup>2</sup>	1.5 mm <sup>2</sup>	1.5 mm <sup>2</sup>	2.5 mm <sup>2</sup>	I <sub>max</sub> * time
LC 60W 12V IP66 slim SNC	14	18	22	28	7	9	12	14	32 A 500 µs
LC 60W 24V IP66 slim SNC	14	18	22	28	7	9	12	14	32 A 500 µs

**CONNECTION**

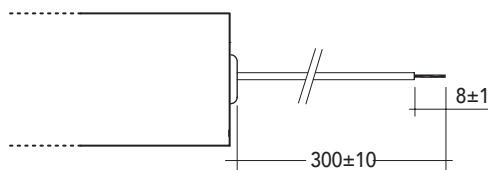

Primary Cable		Secondary Cable	
L	N	+	-
brown	blue	red	black

**WIRING DIAGRAM**

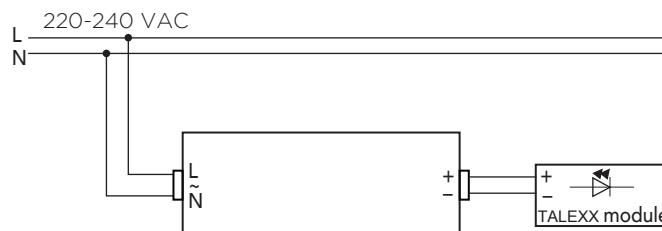

**PRI:**  
Ø 2.8 ±0.2 mm; 2 x 0.82 mm<sup>2</sup> (18 AWG)  
**SEC:**  
12V: Ø 3.1 ±0.2 mm; 2 x 1.31 mm<sup>2</sup> (16 AWG)  
24V: Ø 2.8 ±0.2 mm; 2 x 0.82 mm<sup>2</sup> (18 AWG)

**Installation instructions**

The switching of LEDs on secondary side is not permitted. A proper functioning of the LCU in combination with third party dimming devices (e.g. PWM) cannot be guaranteed.



## STANDARDS

- EN 55015
- EN 61000-3-2
- EN 61000-3-3
- EN 61347-1
- EN 61347-2-13
- EN 61547
- EN 62384

### **Overload protection**

Automatic shutdown of the LED Driver if the maximum output current is exceeded. Automatic restart if the output current is below the limit.

### **No-load operation**

The LED power supply is not damaged in no-load operation. The max. output voltage (see page 1) can be obtained during no-load operation.

### **Over temperature protection**

Automatic shutdown of the LED power supply if the temperature limit is exceeded. Automatic restart if the temperature falls below the limit.

### **Short-circuit behaviour**

In case of a short circuit on the secondary side (LED) the LED power supply switches into hiccupmode. After removal of the short-circuit fault the LED power supply will recover automatically.

## ISOLATION AND ELECTRIC STRENGTH TESTING OF LUMINARIES

Electronic devices can be damaged by high voltage. This has to be considered during the routine testing of the luminaires in production.

According to IEC60598-1 Annex Q (informative only!) or ENEC303-Annex A, each luminaire should be submitted to an isolation test with 500V DC for 1 second. This test voltage should be connected between the interconnected phase and neutral terminals and the earth terminal. The isolation resistance must be at least 2 Mff.

As an alternative, IEC60598-1 Annex Q describes a test of the electrical strength with 1500V AC (or 1.414x1500VDC). To avoid damage to the electronic devices this test must not be conducted.



**DIAGRAMS FOR 12V**

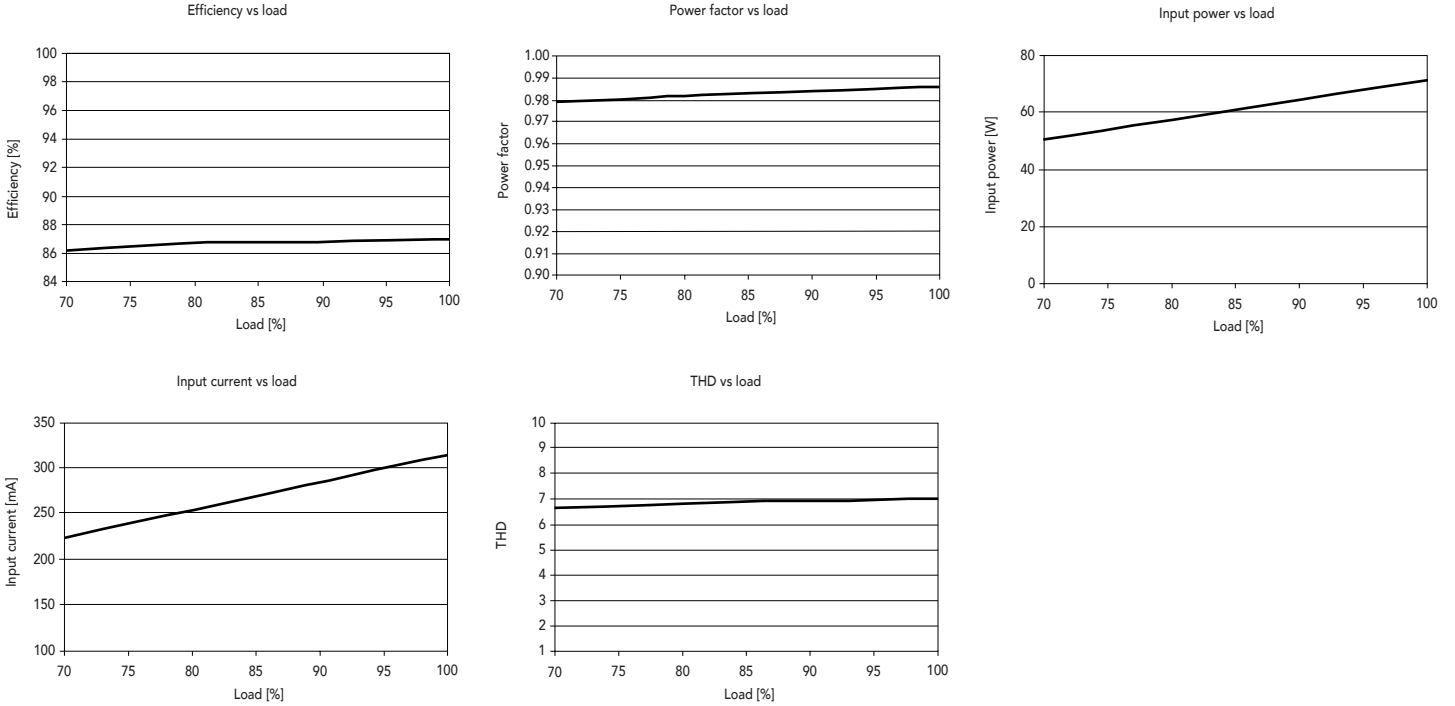

**DIAGRAMS FOR 24V**

