



Product Description:

- Constant voltage LED power supply
- Universal input voltage range
- Constant output voltage
- Connection: Cable with end sleeves (length approx. 500 mm)
- Polarity identifiers, secondary + red / - black
- Metal casing, encapsulated
- Nominal life-time up to 50,000 h (at Ta 50 °C with a failure rate max. 0.2 % per 1,000 h)
- 5-year guarantee
- Suitable for emergency installations according to EN 50172
- Complies with CLASS C from minimum to maximum load range according to EN 61000-3-2

Properties:

- Small design
- High efficiency & Low power loss
- Overtemperature protection w/ automatic restart, Overload protection, Short-circuit protection w/ automatic restart
- SELV
- Type of protection: IP67
- Metal casing



Safety	Standards
USA & Canada	UL 8750, UL 1310, UL 879

ORDERING GUIDE

Type	LCU 100W 12V IP67 TOP
Article Number	28000510
Packaging Carton	10 pc(s).
Packaging Pallet	360 pc(s).
Weight per pc.	0.56 kg

SPECIFIC TECHNICAL DATA

Type	LCU 100W 12V IP67 TOP
Max. Casing Temp Tc	95° C
Output Voltage	12 V
Max. Input Power	117 W
Output Current Range	0.83 - 8.33 A
Max. Output Voltage ¹ 12V	13.2 V

¹ At failure mode (230 V, 50 Hz)

TECHNICAL DATA

Rated Supply Voltage	120 - 277 V
Input Voltage, AC	108 - 305 V
Input Voltage, DC	176 - 288 V
Rated Current (at 230 V, 50 Hz, full load)	0.51 A
Mains Frequency	0 / 50 / 60 Hz
Efficiency (at 230 V, 50 Hz, full load)	> 90%
λ (at 230 V, 50 Hz, full load)	0.95
Output Voltage Tolerance	-0 / +10 %
Output Power (Ta ≤ 60° C)	100 W
Output Power (Ta > 60° C)	80 W
Output Power Range	10 - 100 W
Turn On Time (Output)	≤ 0.5 s
Turn Off Time (Output)	≤ 1 s
Hold on Time at Power Failure (Output)	10 ms
Ambient Temperature Ta	-40 ... +70° C
Ambient Temperature Ta (at life-time 50,000 h)	-40 ... +50° C
Storage Temperature Ts	-40 ... +85° C
Dimensions (L x W x H)	270 x 40 x 23 mm
Hole Spacing	262 x 18 mm



DIMENSION DRAWINGS

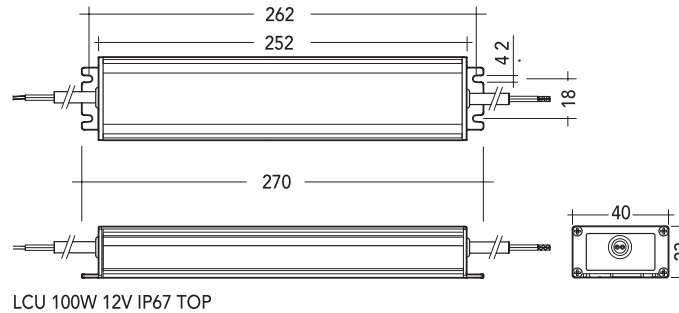

LCU 100W 12V IP67 TOP

EXPECTED LIFE-TIME

Type	Output Voltage	Ta	40° C	50° C	60° C
LCU 100W 12V IP67 TOP	12 V	Tc	60° C	70° C	80° C
		Life-time	> 100,000 h	> 50,000 h	> 25,000 h

HARMONIC DISTORTION IN THE MAINS SUPPLY (AT 230 V / 50 HZ AND FULL LOAD IN %)

Type	THD	3	5	7	9	11
LCU 100W 12V IP67 TOP	10	3	2	2	2	1

MAXIMUM LOADING OF AUTOMATIC CIRCUIT BREAKERS

Automatic Circuit Breaker Type	C10	C13	C16	C20	B10	B13	B16	B20	Inrush Current
Installation Ø	1.5 mm ²	1.5 mm ²	1.5 mm ²	2.5 mm ²	1.5 mm ²	1.5 mm ²	1.5 mm ²	2.5 mm ²	I _{max} * time
LCU 100W 12V IP67 TOP	9	12	15	19	6	7	9	12	51.50 A 99 µs

CONNECTION

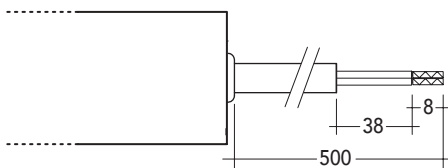

Primary Cable	Secondary Cable
L	+
N	-
brown	blue
	red
	black

PRI:
Ø 7.7 ±0.2 mm; 2 x 1.04 mm² (17 AWG)

SEC:
Ø 8.7 ±0.2 mm; 2 x 2.08 mm² (14 AWG)

WIRING DIAGRAM

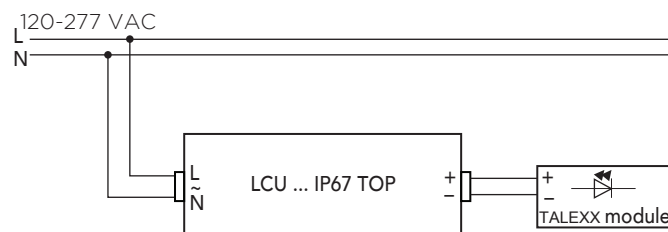

Installation instructions

The switching of LEDs on secondary side is not permitted. A proper functioning of the LCU in combination with third party dimming devices (e.g. PWM) cannot be guaranteed.



STANDARDS

- EN 55015
- EN 60598-1
- EN 60598-2-22
- EN 61000-3-2
- EN 61000-3-3
- EN 61347-1
- EN 61347-2-13
- EN 61547
- EN 62384
- EN 62493
- Acc. to EN 50172: suitabel for central battery systems

Overload protection

Automatic shutdown of the LED Driver if the maximum output current is exceeded. Automatic restart if the output current is below the limit.

No-load operation

The LED power supply is not damaged in no-load operation. The max. output voltage (see page 1) can be obtained during no-load operation.

Over temperature protection

Automatic shutdown of the LED power supply if the temperature limit is exceeded. Automatic restart if the temperature falls below the limit.

Short-circuit behaviour

In case of a short circuit on the secondary side (LED) the LED power supply switches into hiccupmode. After removal of the short-circuit fault the LED power supply will recover automatically.

ISOLATION AND ELECTRIC STRENGTH TESTING OF LUMINARIES

Electronic devices can be damaged by high voltage. This has to be considered during the routine testing of the luminaires in production. According to IEC60598-1 Annex Q (informative only!) or ENEC303-Annex A, each luminaire should be submitted to an isolation test with 500V DC for 1 second. This test voltage should be connected between the interconnected phase and neutral terminals and the earth terminal.

The isolation resistance must be at least 2 Mff. As an alternative, IEC60598-1 Annex Q describes a test of the electrical strength with 1500V AC (or1.414x1500VDC).To avoid damage to the electronic devices this test must not be conducted.

DIAGRAMS FOR 12V

