



Product Description:

- Constant voltage LED power supply
- Universal input voltage range
- Constant output voltage
- Connection: Cable with end sleeves (length approx. 500 mm)
- Polarity identifiers, secondary + red / - black
- Metal casing, encapsulated
- Nominal life-time up to 50,000 h (at Ta 50 °C with a failure rate max. 0.2 % per 1,000 h)
- 5-year guarantee
- Suitable for emergency installations according to EN 50172
- Complies with CLASS C from minimum to maximum load range according to EN 61000-3-2

Properties:

- Small design
- High efficiency & Low power loss
- Overtemperature protection w/ automatic restart, Overload protection, Short-circuit protection w/ automatic restart
- SELV
- Type of protection: IP67
- Metal casing



ORDERING GUIDE

Type 12V	LCU 180W 12V IP67 TOP
Type 24V	LCU 180W 24V IP67 TOP
Article Number 12V	28000511
Article Number 24V	28000514
Packaging Carton 12V	10 pc(s).
Packaging Carton 24V	10 pc(s).
Packaging Pallet 12V	300 pc(s).
Packaging Pallet 24V	400 pc(s).
Weight per pc. 12V	0.98 kg
Weight per pc. 24V	0.90 kg

SPECIFIC TECHNICAL DATA

Type 12V	LCU 180W 12V IP67 TOP
Type 24V	LCU 180W 24V IP67 TOP
Max. Casing Temp T _c (both)	85° C
Output Voltage 12V	12 V
Output Voltage 24V	24 V
Max. Input Power (both)	211 W
Output Current Range 12V	1.50 - 15.0 A
Output Current Range 24V	0.75 - 7.5 A
Max. Output Voltage ¹ 12V	13.2 V
Max. Output Voltage ¹ 24V	25.2 V

Safety	Safety Standards
UL / cUL	UL 8750,
Country	UL 1310,
USA & Canada	UL 879

TECHNICAL DATA

Rated Supply Voltage	120 - 277 V
Input Voltage, AC	108 - 305 V
Input Voltage, DC	176 - 288 V
Rated Current (at 230 V, 50 Hz, full load)	0.92 A
Mains Frequency	0 / 50 / 60 Hz
Efficiency (at 230 V, 50 Hz, full load)	> 90%
λ (at 230 V, 50 Hz, full load)	0.95
Output Voltage Tolerance	-0 / +5 %
Output Power (T _a ≤ 60° C)	180 W
Output Power (T _a > 60° C)	144 W
Output Power Range	18 - 180 W
Turn On Time (Output)	≤ 0.5 s
Turn Off Time (Output)	≤ 1 s
Hold on Time at Power Failure (Output)	10 ms
Ambient Temperature T _a	-40 ... +70° C
Ambient Temperature T _a (at life-time 50,000 h)	-40 ... +50° C
Storage Temperature T _s	-40 ... +85° C
Dimensions (L x W x H) 24V	245 x 60 x 29 mm
Dimensions (L x W x H) 12V	270 x 60 x 29 mm
Hole Spacing 24V	237 x 32 mm
Hole Spacing 12V	262 x 32 mm



DIMENSION DRAWINGS

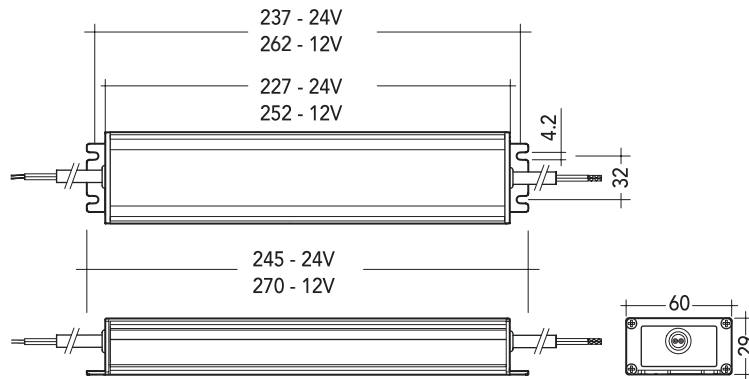

EXPECTED LIFE-TIME

Type	Output Voltage	Ta	40° C	50° C	60° C
LCU 180W 12V IP67 TOP	12 V	Tc	67° C	77° C	87° C
		Life-time	> 100,000 h	> 50,000 h	> 25,000 h
		Tc	65° C	75° C	82° C
LCU 180W 24V IP67 TOP	24 V	Tc	65° C	75° C	82° C
		Life-time	> 100,000 h	> 50,000 h	> 25,000 h
		Tc	65° C	75° C	82° C

HARMONIC DISTORTION IN THE MAINS SUPPLY (AT 230 V / 50 HZ AND FULL LOAD IN %)

Type	THD	3	5	7	9	11
LCU 180W 12V IP67 TOP	15	13	4	2	1	1
LCU 180W 24V IP67 TOP	15	13	4	2	1	1

MAXIMUM LOADING OF AUTOMATIC CIRCUIT BREAKERS

Automatic Circuit Breaker Type	C10	C13	C16	C20	B10	B13	B16	B20	Inrush Current
Installation Ø	1.5 mm ²	1.5 mm ²	1.5 mm ²	2.5 mm ²	1.5 mm ²	1.5 mm ²	1.5 mm ²	2.5 mm ²	I _{max} * time
LCU 180W 12V IP67 TOP	9	12	15	18	9	12	15	18	95.5 A 120 µs
LCU 180W 24V IP67 TOP	9	12	15	18	9	12	15	18	64.0 A 150 µs

CONNECTION

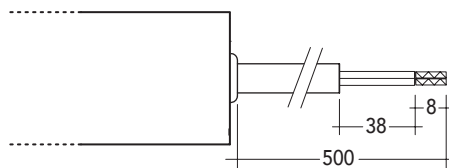

Primary Cable		Secondary Cable	
L	N	+	-
brown	blue	red	black

PRI:

Ø 7.7 ±0.2 mm; 2 x 1.04 mm² (17 AWG)

SEC:

Ø 8.7 ±0.2 mm; 2 x 2.08 mm² (14 AWG)

WIRING DIAGRAM

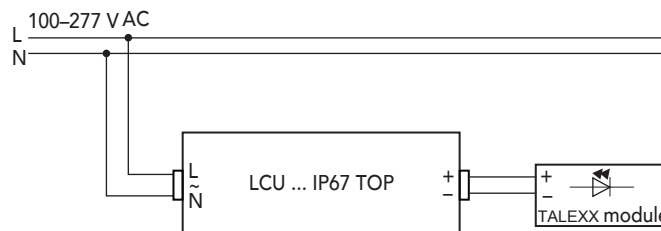

Installation instructions

The switching of LEDs on secondary side is not permitted. A proper functioning of the LCU in combination with third party dimming devices (e.g. PWM) cannot be guaranteed.



STANDARDS

- EN 55015
- EN 60598-1
- EN 60598-2-22
- EN 61000-3-2
- EN 61000-3-3
- EN 61347-1
- EN 61347-2-13
- EN 61547
- EN 62384
- EN 62493
- Acc. to EN 50172: suitabel for central battery systems

Overload protection

Automatic shutdown of the LED Driver if the maximum output current is exceeded. Automatic restart if the output current is below the limit.

No-load operation

The LED power supply is not damaged in no-load operation. The max. output voltage (see page 1) can be obtained during no-load operation.

Over temperature protection

Automatic shutdown of the LED power supply if the temperature limit is exceeded. Automatic restart if the temperature falls below the limit.

Short-circuit behaviour

In case of a short circuit on the secondary side (LED) the LED power supply switches into hiccupmode. After removal of the short-circuit fault the LED power supply will recover automatically.

ISOLATION AND ELECTRIC STRENGTH TESTING OF LUMINARIES

Electronic devices can be damaged by high voltage. This has to be considered during the routine testing of the luminaires in production. According to IEC60598-1 Annex Q (informative only!) or ENEC303-Annex A, each luminaire should be submitted to an isolation test with 500V DC for 1 second. This test voltage should be connected between the interconnected phase and neutral terminals and the earth terminal. The isolation resistance must be at least 2 Mff. As an alternative, IEC60598-1 Annex Q describes a test of the electrical strength with 1500V AC (or 1.414x1500VDC). To avoid damage to the electronic devices this test must not be conducted.

DIAGRAMS FOR 12V

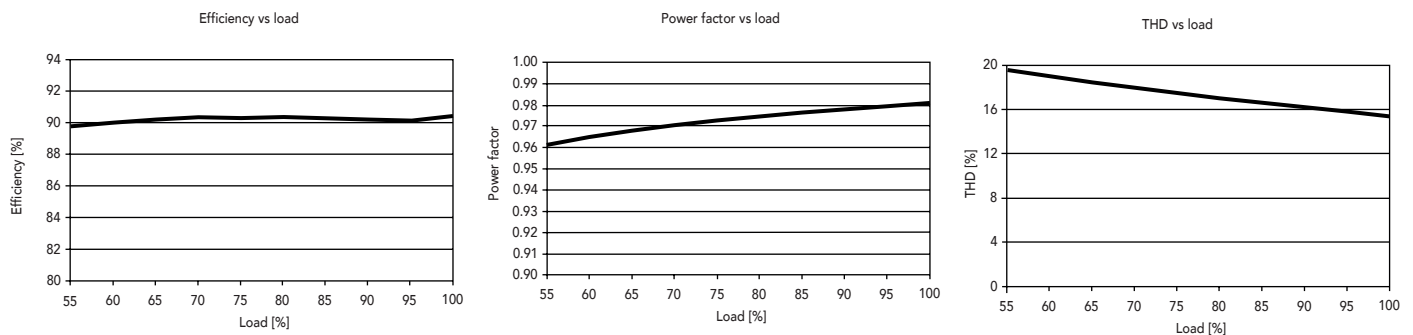

DIAGRAMS FOR 24V

