

MINI

1. Tilt the fixture top to one side and position the fixture at the desired location.

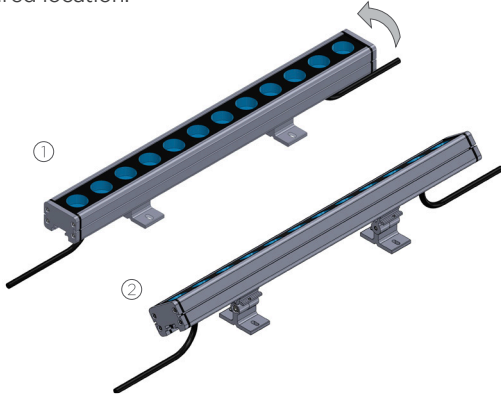

2. Secure the fixture in place by fastening the screws through the screw holes on one side of the tiltable stand.

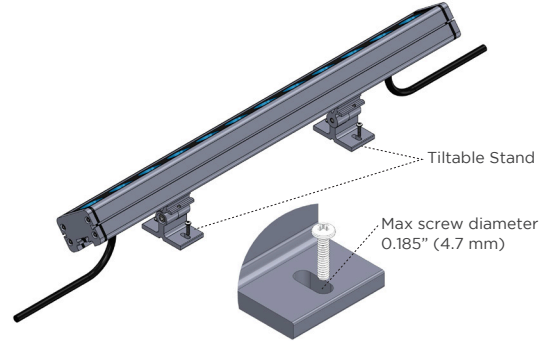

3. Rotate the fixture in the opposite direction and fasten the screws on the other side of the tiltable stand.



4. Connect input cable to the power supply. Daisy-chain the connector on the opposite end to the next fixture if desired.

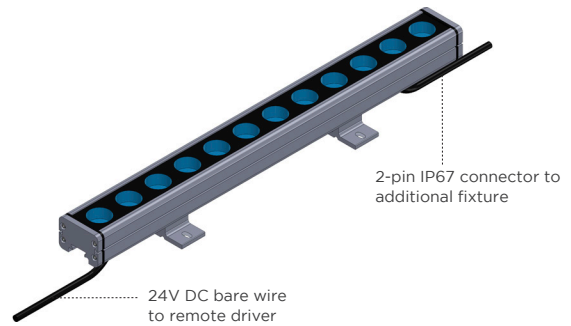

NANO

1. Tilt the fixture top to one side and position the fixture at the desired location.

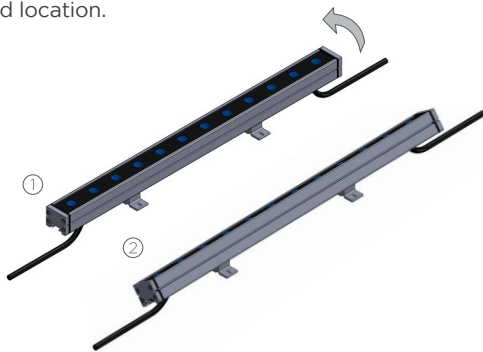

2. Fasten screws through the screw holes on the tiltable stands.

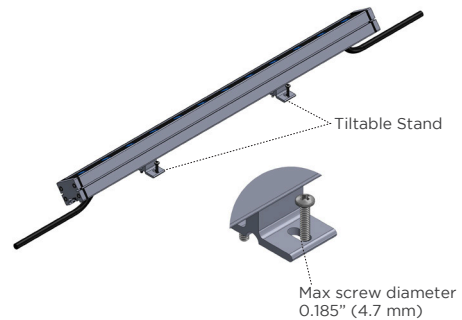

3. Tilt the fixture top to the other side and fasten screws through second set of screw holes on the tiltable stands (same as Step 2).



4. Connect to power supply and to additional fixture if desire to complete the installation.

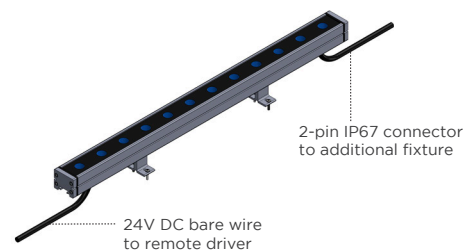

Note: Mounting arms need to be installed with proper damping hardware in extreme vibration environments

1. Use proper screws (screw size up to 1/4" or M6.5) to mount one extension arm onto the wall.

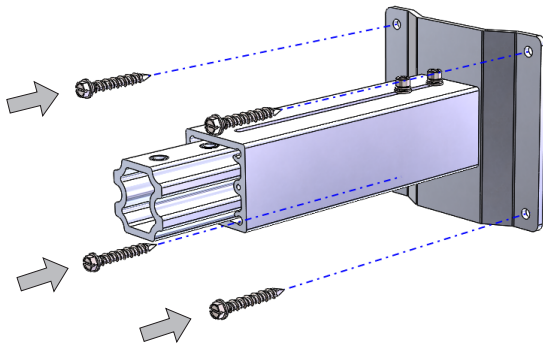

2. Mount the other arm onto the wall. Make sure the distance (D) is the same as the tiltable stands distance (D) on the fixture.

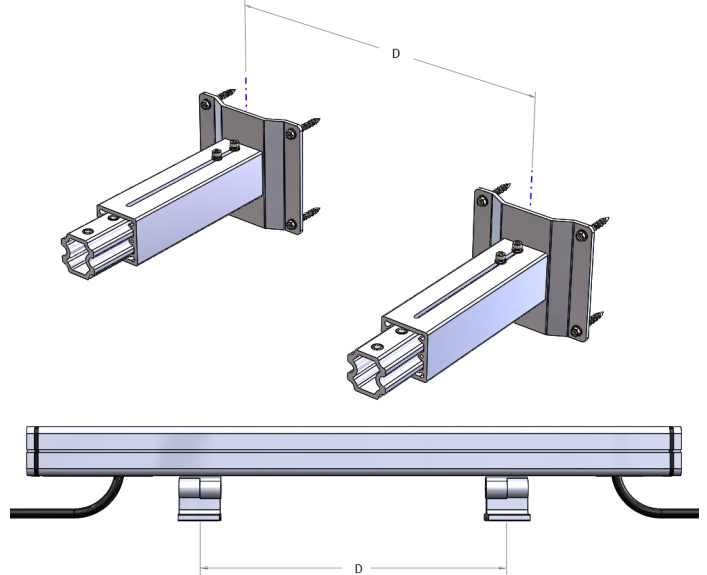

3. Use L-Key (M4) to loosen the hex socket screws and adjust the inner channels to the desired arm length. Then tighten the screws to secure the inner channels.

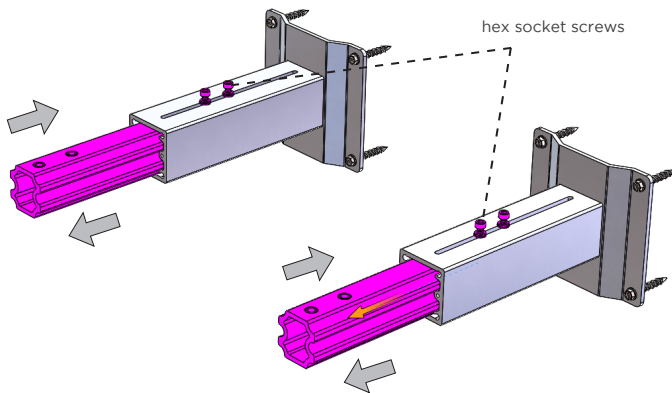

4. Loosen the set screws and adjust the position of the tiltable stand if it's misaligned to the extension arms.

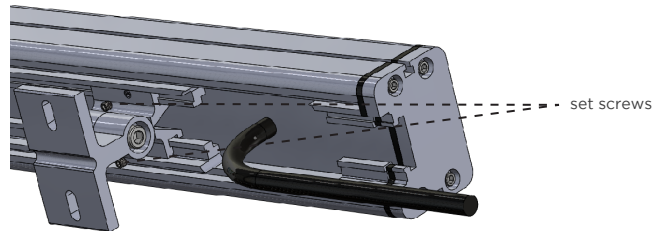

5. Secure the fixture on the pair of extension arms by fastening the screws in the tiltable stand to the extension arms. (See Step 1-4 for reference)

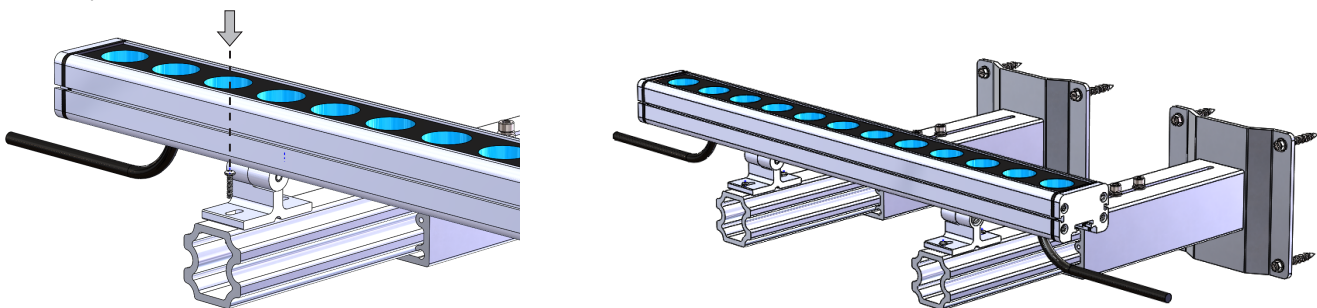

1. Screw the copper standoffs to the Glare Shield using a hex nut standoff driver.

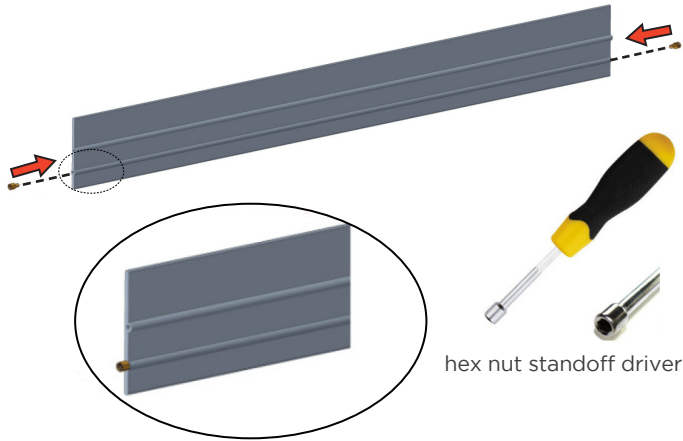

2. Slide the Glare Shield mounting bracket onto the fixture near the end cap. Be sure not to cover any LEDs. Secure the Glare Shield by fastening screws to the side of the bracket.

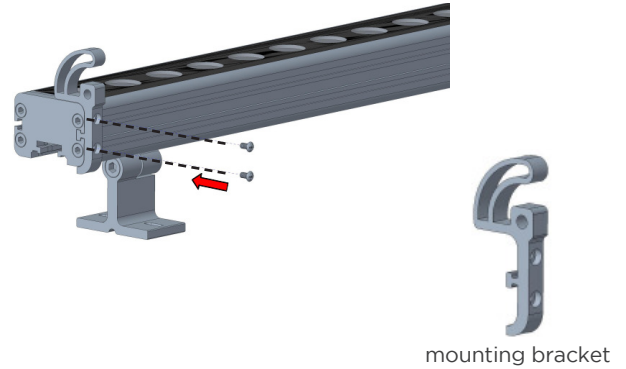

3. Align the screw bosses on the Glare Shield with the screw holes on the mounting bracket.

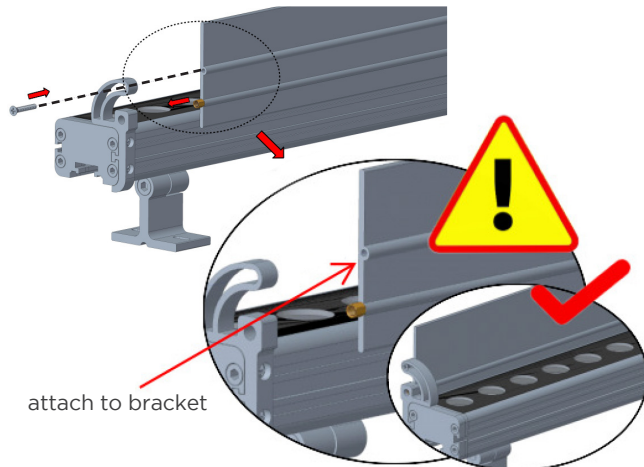

4. Put the copper standoff through the lower screw hole on the mounting bracket. Fasten the flathead screw through the top slot in the mounting bracket into the Glare Shield.

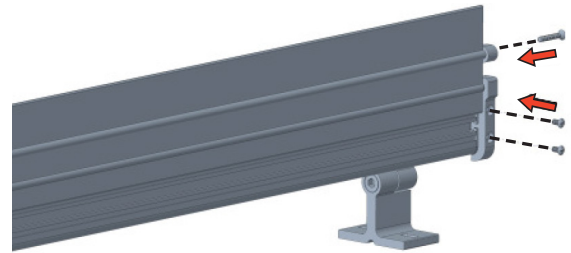

5. Repeat steps on the opposite side of the fixture.

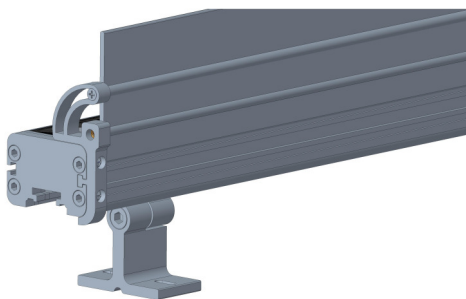

6. Tighten/loosen the flathead screws and rotate the Glare Shield until it is set at the desired angle.

