

6 UNIVERSE DMX CONTROLLER

The 6 Universe DMX Controller is an incredibly durable solution for complex fixed lighting installations. Control up to six universes – as many as 3,072 channels – over DMX, LED Pixel or DALI protocols. Synchronize 2,000 scenes over 20 zones in large-scale lighting projects with one controller. Program fades, bursts, scenes and sequences with a PC or Mac over USB/Ethernet or use an on-site programming app with your smartphone or tablet. The 6 Universe DMX Controller offers multiple triggers for your light scenes based on time, date, event or myriad specific assignable conditions. A single unit allows individual control over up to 1,024 RGB or 768 RGBW devices.

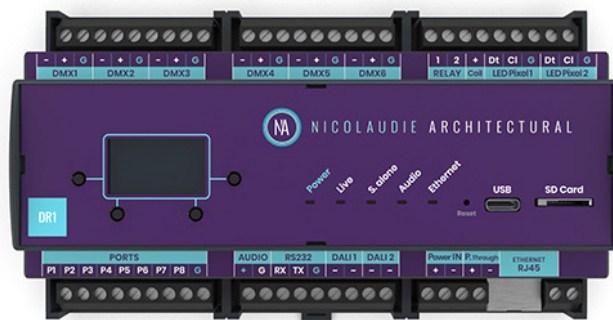

- 3,072 channels
- 20 zones
- 2,000 scenes
- 16 mb internal memory
- Micro SD card
- 8-15 VDC power
- 8 ports
- Clock/calendar triggers
- Optional audio/DALI triggers
- Control with iOS/Android apps
- Program with PC/Mac or iOS/Android

ORDERING GUIDE

Category

DMXCTRLDR6U

DMXCTRLDR6U - 6 Universe DMX Controller

SPECIFICATIONS

| | |
|------------------------|--|
| Input Power | 12 VDC (8-15 V range) |
| Output Protocol | DMX512 (x6), eDMX, LED Pixel (SPIx2) |
| Programmability | PC (Windows 7/8/10), Mac (Windows 7/8/10), Android, iOS |
| Connections | USB-C, Ethernet Screw terminals (for 6 DMX / RDM Universes, 2 DALI loops 2021, LED Pixel 2021, 8 Contact ports, Relay, 12V power-in & p.through, RS232 scene trigger, Audio in <sound to light>), Battery holder (CR2032), Micro SD slot |
| Memory | 16MB flash, SD Card |
| IP Rating | IP20 |
| Operating Temperature | 32 – 122 °F (0 – 50 °C) |
| Standards | EC, EMC, ROHS |
| Dimensions (L x W x D) | 6.3 x 3.58 x 2.44 in. (160 x 91 x 62 mm) |
| Weight | 0.7 lb (317 g) |

Acolyte does not warrant or represent that the information is free from errors or omission. The information may change without notice and Acolyte is not in any way liable for the accuracy of any information printed and stored or in any way interpreted or used.

CONNECTIONS

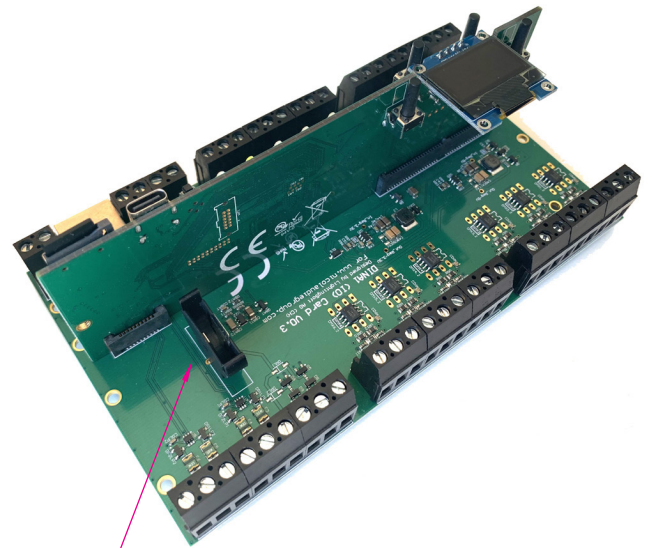
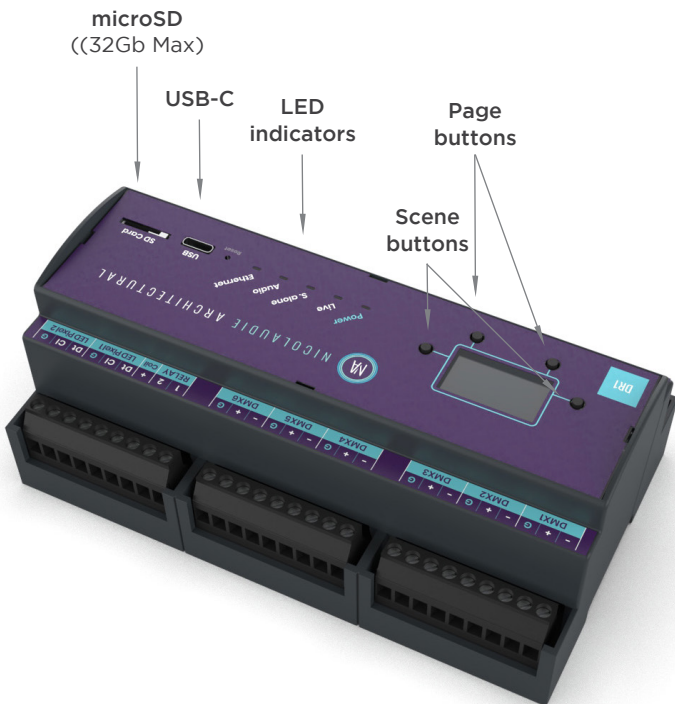
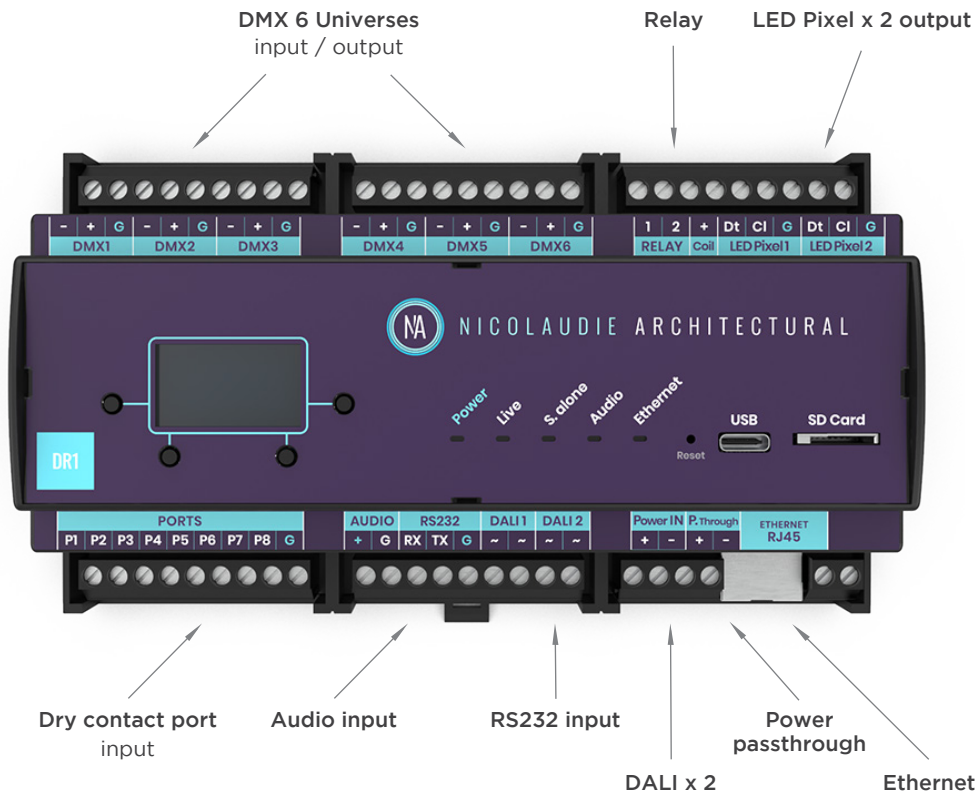

INSTALLATION / SETTINGS

Easy Installation

1. Mount a DIN Rail or DIN Rail Encloser against a wall

2. Connect the wires

POWER: Connect 12 VDC ACDC supply. The 6 Universe DMX Controller can accept 8v-15v.

Be sure to not invert the + and the ground.

DMX: Connect the DMX cables from one of the 6 universes to the lighting receivers.

3. Clip the 6 Universe DMX Controller onto the DIN RAIL

On the back of the interface housing is a channel designed to accept a DIN Rail with a black plastic clip which secures the interface.

To mount: Slide the mounting teeth behind the top of the rail and then rotate downwards to engage the clip.

To dismount: At the lower edge of the interface you will see a plastic clip. Pull this down to release interface from the rail.

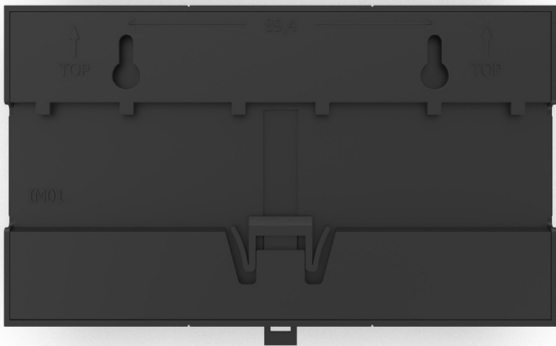

Setting up the controller

The controller can be programmed from a PC, Mac, iOS (Apple) or Android device using the software listed below. Refer to the corresponding software manual for more information. Firmware and settings can be updated using Hardware Manager (installed with PC/Mac programming software) or with Hardware Tools.

Windows / Mac Programming Software

ESA Pro 2 - Multizone

www.nicolaudie.com/esapro2.htm

ESA2 - Single Zone

www.nicolaudie.com/esa2.htm

Hardware Manager - For Firmware, time/date

Find this under Tools @ nicolaudie.com/download.htm

Apple iOS and Android Apps

Arcolis - Search for 'Arcolis' on the Google Play

Store and iOS App Store

Hardware Tools - Search for 'Hardware Tools' on the iOS App Store or on Google Play for Android devices.

INSTALLATION / SETTINGS

Connections & Triggering

DMX512

Connect up to 6 DMX universes and 2,000 scenes for the 6 Universe DMX Controller. It is possible to buy extra DMX universes for the controller to reach the maximum number of channels.

LED Indicators

- POWER: Orange LED is ON when the interface is powered.
- LIVE: Green LED is ON when software or an app communicates with the controller.
- S. ALONE: Red LED is ON when the controller runs in Stand Alone mode.
- AUDIO: White LED is FLASHING when the controller receives an audio signal.
- ETHERNET: Blue LED is FLASHING when the controller is connected to a local network.

Audio

It is possible to directly connect an analog audio source to the 6 Universe DMX Controller in order to trigger your lighting scenes with the beat of the music. Simply connect a line level signal to the controller.

The programming/configuration must be done with ESA Pro 2 software like any other TCA trigger. You can decide to make a scene jump from step to step according to the beat.

When an audio signal is received by the controller, the AUDIO LED (white) will flash.

Ports

- Use up to 8 external trigger ports (dry contacts).
- Connect G and P1 to start Port #1.
- Connect G and P2 to start Port #2, and so on.
- Ports can be programmed in your show file (TCA).

RS232

Make a cable using the 3 pins: RX, TX and G (GND).

Set the RS232 parameters to: 9600 bds 8 bits, no Parity, 2 Stop bits.

Messages should be hexadecimal (i.e., 1=01, 255=FF etc.).

- To play a scene, send 4 bytes: 1 x y 255
- To stop a scene, send 4 bytes: 2 x y 255
- To pause a scene, send 4 bytes: 3 x y 255
- To release a pause, send 4 bytes: 4 x y 255
- To reset a scene, send 4 bytes: 5 x y 255

When (y)=0, (x) can be set between 0 and 255.

- To stop scene 145, send the command: 2 145 0 255

When (y)=1, (x) can be set between 0 and 243 to trigger scenes 256-499.

- To play scene 300, send the command: 1 44 1 255

A page can contain 1 to 2,000 scenes as long as the total number on all pages does not exceed 2,000. The index of a scene can be found by looking in the file /show1/show_map.xml after writing a scene.

General examples:

0x01 0x02 0x00 0xFF to call scene 2.

0x01 0x05 0x00 0xFF to call scene 5.

0x01 0x10 0x05 0xFF to call scene 1296.

Hardware Settings Display

It is possible to display most of the controller settings from the device screen. Simply press and hold the 2 zone buttons for 2 seconds to display the settings. You can then navigate with the scene buttons. Repeat the operation to leave the display mode. The most important settings can be visualized from the device display: date/time, firmware version, serial number, network settings, etc. It is also possible to visualize the controller performances (CPU, memory, etc.).

Log Management

The 6 Universe DMX Controller offers the possibility to store activity logs on an SD Card or on a SysLog server. This option can be activated from the Hardware Manager program (Settings tab) and could be very helpful to service an installation. We recommend that you activate the SD Card option on demand only (debugging operation) to lower the SD Card access.

WIRING DIAGRAMS WITH RGBW ADDRESSABLE RIBBONLYTE

One DMX Universe consists of 128 addresses and 512 channels (42 ft / 12.8 m of RibbonLyte).

Any single run of RibbonLyte that is less than 16 ft 4 in. / 5 m can be wired directly to the controller.

For additional runs, Opto Splitter must be used. Each individual run will need its own Opto Splitter output.

| WIRE INDEX | |
|------------|-----------|
| + | (24V +) |
| PI | (DMX GND) |
| A+ | (DMX +) |
| B- | (DMX -) |
| GND | (24V -) |

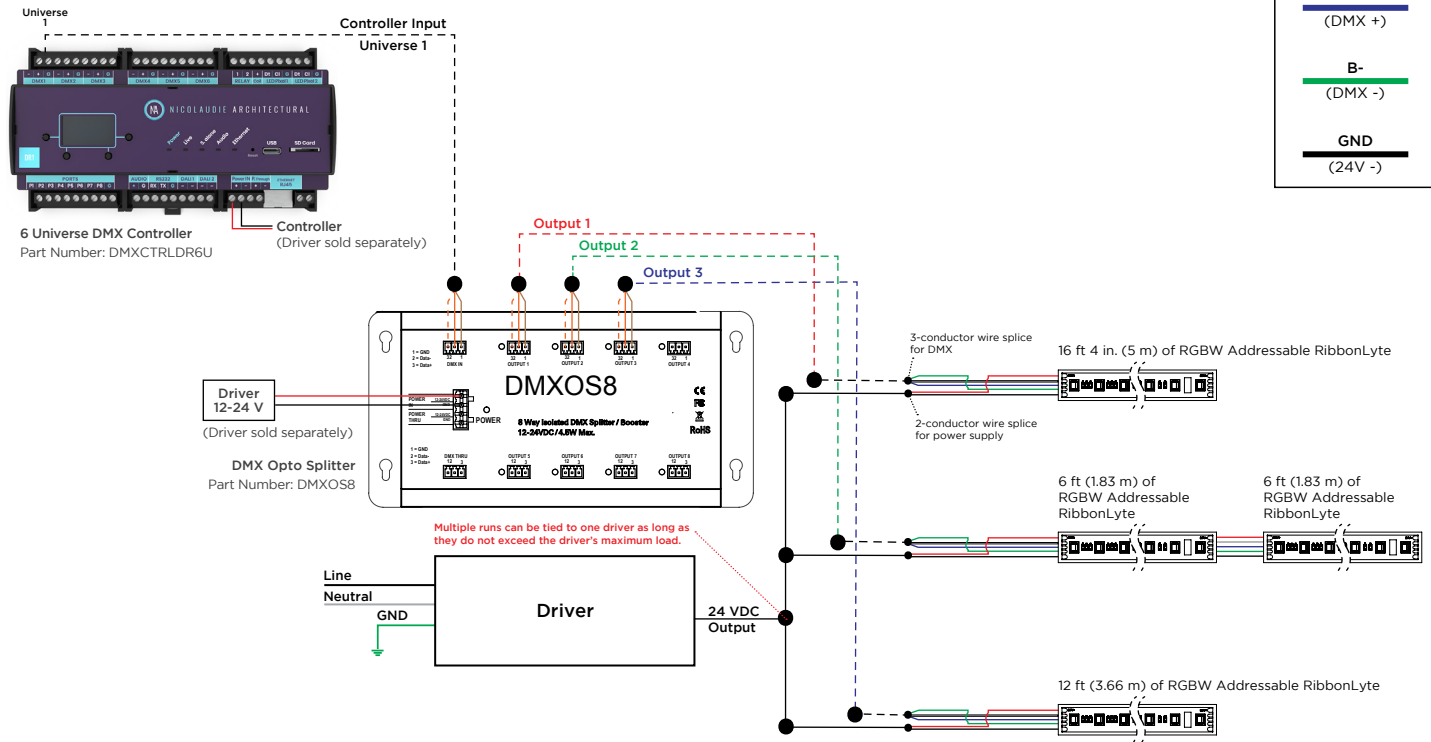

MAX LENGTH BETWEEN DRIVER & RIBBONLYTE AT FULL LOAD

| Wattages | 40 | | 60 | | 96 + 100 | | 150 | | 200 | | 240 | | 300 | | 320 | |
|----------|------|--------|------|--------|----------|--------|------|--------|------|--------|------|--------|------|--------|------|--------|
| | Feet | Meters | Feet | Meters | Feet | Meters | Feet | Meters | Feet | Meters | Feet | Meters | Feet | Meters | Feet | Meters |
| 24 AWG | 14 | 4.27 | 9 | 2.74 | 5.5 | 1.68 | 3.75 | 1.14 | 2.75 | 0.84 | 2.25 | 0.69 | 1.75 | 0.53 | 1.75 | 0.53 |
| 22 AWG | 22 | 6.71 | 14 | 4.27 | 9 | 2.74 | 5.75 | 1.75 | 4.5 | 1.37 | 3.5 | 1.07 | 2.75 | 0.84 | 2.75 | 0.84 |
| 20 AWG | 35 | 10.67 | 23 | 7.01 | 14 | 4.27 | 9 | 2.74 | 7 | 2.13 | 5.75 | 1.75 | 4.5 | 1.37 | 4.25 | 1.30 |
| 18 AWG | 56 | 17.07 | 37 | 11.28 | 23 | 7.01 | 15 | 4.57 | 11 | 3.35 | 9 | 2.74 | 7.5 | 2.29 | 7 | 2.13 |
| 16 AWG | 90 | 27.44 | 60 | 18.29 | 37 | 11.28 | 24 | 7.32 | 18 | 5.49 | 15 | 4.57 | 12 | 3.66 | 11 | 3.35 |
| 14 AWG | 142 | 43.29 | 95 | 28.96 | 59 | 17.99 | 38 | 11.59 | 28 | 8.54 | 23 | 7.01 | 19 | 5.79 | 17 | 5.18 |
| 12 AWG | 226 | 68.90 | 151 | 46.04 | 94 | 28.66 | 60 | 18.29 | 45 | 13.72 | 37 | 11.28 | 30 | 9.15 | 28 | 8.54 |
| 10 AWG | 360 | 109.76 | 240 | 73.17 | 150 | 45.73 | 96 | 29.27 | 72 | 21.95 | 60 | 18.29 | 48 | 14.63 | 45 | 13.72 |
| 8 AWG | 574 | 175.00 | 381 | 116.16 | 239 | 72.87 | 153 | 46.65 | 115 | 35.06 | 95 | 28.96 | 76 | 23.17 | 71 | 21.65 |

WIRING DIAGRAM WITH RGBW, RGBA & VARIABLE WHITE RIBBONLYTE

DMX

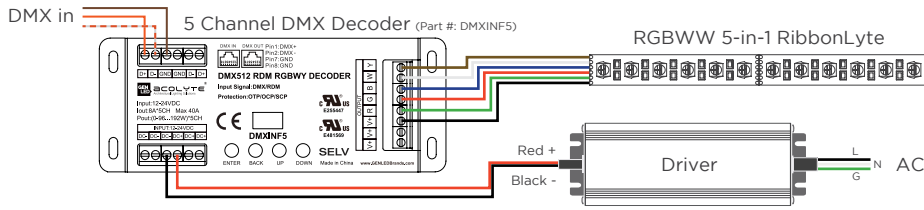

WIRE COLORS PER RIBBONLYTE COLOR

RGBW & RGBA

Black Wire (+) Positive
Red Wire (-) goes to Red Channel
Green Wire (-) goes to Green Channel
Blue Wire (-) goes to Blue Channel
White Wire (-) goes to White Channel

RGBWW

Black (+) Positive
Green Wire (-) goes to Green Channel
Red Wire (-) goes to Red Channel
Blue Wire (-) goes to Blue Channel
White Wire (-) goes to White Channel 1
Brown Wire (-) goes to White Channel 2

DMX WIRING DIAGRAM - COMPATIBLE WITH ALL MODELS OF VARIABLE WHITE RIBBONLYTE

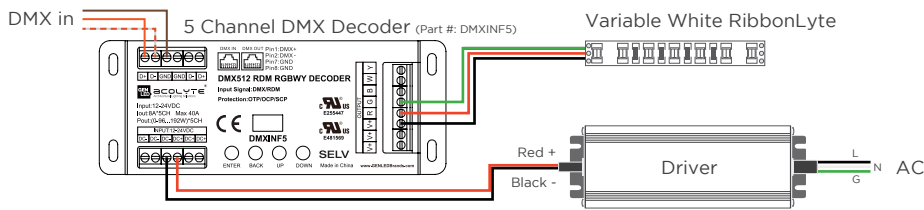

VARIABLE WHITE

Black Wire (+) Positive
Red Wire (-) goes to Warm White Channel
Green Wire (-) goes to Cool White Channel

REV.08MAY2026

GLOBAL HQ

320 Murray Hill Pkwy
East Rutherford, NJ 07073
U.S.
T: (+1) 212 629 6830
E: Sales-US@GENLEDBrands.com

EUROPEAN HQ

Hogeweyselaan 119
1382 JK Weesp
Netherlands
T: (+31) 346 235 000
E: SalesEurope@GENLEDBrands.com

MEINA HQ

PO Box 371378, #823, Building 4EA
Dubai Airport Free Zone
Dubai, UAE
T: (+971) 4 701 7901
E: SalesMEINA@genlebrands.com

ASIA-PACIFIC HQ

Room 402, Building D
Shenshi Tongchuang Science and Technology Park
No. 16 Hongyin Road
Xingqiang Community, Xihu Street
Guangming District, Shenzhen, China 518107
T: (+86) 755 8529 0710
E: Sales-Pacific@GENLEDBrands.com