

**EN** Installation instruction:

- > The module chain can be cut between each module to the necessary length (fig. 1 and 2).
- > When mounting the modules, they should be spaced equally to ensure uniform illumination.
- > Clean the mounting surfaces thoroughly before sticking down the modules, for example, using isopropyl alcohol diluted with water (50:50).
- > The tape on the modules attain their full strength only after approx. 24 hours. Be sure to press firmly on each module to activate the adhesive.
- > Disposal of packaging in compliance with the local laws.

**⚠ DANGER!**  
Hazard of death by electrocution

- > Before connecting the power supply, disconnect the main electrical lines.
- > Ensure that the modules are dry when mounting.

**WARNING!**  
Improper mounting can reduce the life of the modules or cause them to fail within a short time!

- > Observe ambient temperature: -40 ... +60 °C
- > Observe max. surface temperature: 69/79°C
- > Observe max. permissible operating voltage: 12 V DC -0.6 V / +1.2 V
- > Observe polarity: red (+); white (-)
- > To ensure compliance with type of protection IP68, use appropriate connectors, end ferrules and grommets on the casing.
- > Observe the product and wiring specifications listed in the data sheet.

**FR** Instruction de montage :

- > La chaîne modulaire peut être coupée sur la longueur désirée (fig. 1 et 2).
- > Pour garantir un éclairage uniforme, veiller à respecter la même distance entre les modules lors du montage.
- > Avant de coller les modules, nettoyer les surfaces de montage à fond avec des nettoyants appropriés, comme l'isopropanol dilué dans l'eau (50-50).
- > Les surfaces adhésives des modules n'atteignent leur résistance définitive qu'après 24 h environ. Veuillez vous assurer d'appuyer fermement sur chaque module à l'adhésif.
- > Éliminer l'emballage correctement en respectant les prescriptions locales en vigueur.

**⚠ DANGER !**  
Danger de mort dû à l'électrocution

- > Avant le raccordement du convertisseur, couper la tension d'alimentation.
- > Monter les modules à l'état sec.

**NOTE !**  
Un montage incorrect risque de se traduire par une durée de vie moindre et une défaillance des modules à court terme !

- > Respecter la température ambiante : -40 ... +60 °C
- > Respecter la température de surface maximale : 69/79°C
- > Respecter la tension de service max. admissible : 12 V DC -0.6 V / +1.2 V
- > Respecter la polarité : rouge (+); blanc (-)
- > Pour conserver l'indice de protection IP68, il faut utiliser des connexions, bagues d'extrémité et passages de boîtiers respectifs.
- > Respecter les indications concernant le produit et le câblage dans la fiche technique.

**ES** Instrucción de montaje:

- > La cadena de los módulos se puede adaptar a la longitud necesaria (fig. 1 y 2).
- > Para que la iluminación sea uniforme, los módulos tienen que montarse guardando la misma distancia entre sí.
- > Antes de pegar los módulos, hay que limpiar bien la zona de montaje con un limpiador adecuado, p. ej., con una mezcla de isopropanol/agua (50-50).
- > Las superficies adhesivas de los módulos tardan unas 24 horas en alcanzar su capacidad completa de adherencia. Presione firme cada módulo para activar el adhesivo.
- > Hay que deshacerse de los envases de forma adecuada de conformidad con la legislación local vigente.

**⚠ ¡PELIGRO!**  
Peligro de muerte por descarga eléctrica

- > Desconectar la tensión de alimentación antes de conectar el convertidor.
- > Montar los módulos cuando estén secos.

**¡ADVERTENCIA!**  
¡Un montaje efectuado de forma incorrecta puede reducir la vida útil o provocar que los módulos fallen a corto plazo!

- > Observar la temperatura ambiente: -40 ... +60 °C
- > Observar la temperatura máx. de las superficies: 69/79°C
- > Observar la tensión de servicio máx. admisible: 12 V DC -0.6 V / +1.2 V
- > Observar la polaridad: rojo (+); blanco (-)
- > Para mantener el modo de protección IP68 hay que usar conexiones, manguitos de empalme y pasos de cables de caja adecuados.
- > Observar los datos de la ficha técnica del producto y del cableado.

**IT** Istruzioni di montaggio:

- > la catena può essere tagliata per ottenere la lunghezza desiderata (fig. 1 e 2).
- > Per ottenere un'illuminazione uniforme, i moduli dovrebbero essere montati alla stessa distanza tra di loro.
- > Prima di incollare i moduli, pulire accuratamente la superficie di montaggio con un detergente idoneo, p. es. miscela di acqua- alcool (50-50).
- > il bi adesivo di montaggio dei moduli raggiunge piena rigidità solo dopo 24 ore circa.
- > Smaltire a regola d'arte la confezione, secondo le leggi locali vigenti.

**⚠ PERICOLO!**  
Pericolo di morte dovuto da scossa elettrica

- > Staccare la tensione di rete prima di collegare l'alimentatore.
- > Montare i moduli in un ambiente asciutto.

**ATTENZIONE!**  
Un montaggio sbagliato può ridurre l'aspettativa di vita dei moduli o danneggiarli in maniera permanente.

- > Rispettare il range di temperatura ambiente: -40 ... +60 °C
- > Non eccedere la temperatura massima sul modulo : 69/79°C
- > Rispettare la tensione d'esercizio massima consentita: 12 V DC -0.6 V / +1.2 V
- > Rispettare la polarità: rosso (+); bianco (-)
- > Per mantenere il grado di protezione IP68, utilizzare collegamenti e morsetti idonei
- > Osservare le indicazioni e informazioni riportate nella scheda tecnica del prodotto e per il cablaggio.

**DE** Montageanleitung:

- > Die Modulkette kann auf die jeweils benötigte Länge zugeschnitten werden (Abb. 1 und 2).
- > Für eine gleichmäßige Ausleuchtung sollen die Module im gleichen Abstand zueinander montiert werden.
- > Vor dem Aufkleben der Module Montageflächen gründlich mit geeignetem Reinigungsmittel, z. B. Isopropanol-Wasser (50-50) reinigen.
- > Die Klebeflächen der Module erreichen ihre volle Festigkeit erst nach ca. 24 Stunden. Drücken Sie fest auf beiden Modulen um das Klebstoff zu aktivieren.
- > Verpackung gemäß den örtlich geltenden Gesetzen fachgerecht entsorgen.

**⚠ GEFAHR!**  
Lebensgefahr durch Stromschlag

- > Vor dem Anschluss des Konverters Netzspannung trennen.
- > Module im trockenen Zustand montieren.

**HINWEIS!**  
Falsche Montage kann die Lebensdauer reduzieren oder die Module können kurzfristig ausfallen!

- > Umgebungstemperatur beachten: -40 ... +60 °C
- > Max. Oberflächentemperatur beachten: 69/79°C
- > Max. zulässige Betriebsspannung beachten: 12 V DC -0.6 V / +1.2 V
- > Polarität beachten: rot (+); weiß (-)
- > Zum Erhalt der Schutzart IP68 entsprechende Verbindungen, Endhülsen und Gehäusedurchführungen verwenden.
- > Angaben im Datenblatt zum Produkt und zur Verdrahtung beachten.



**IP67**

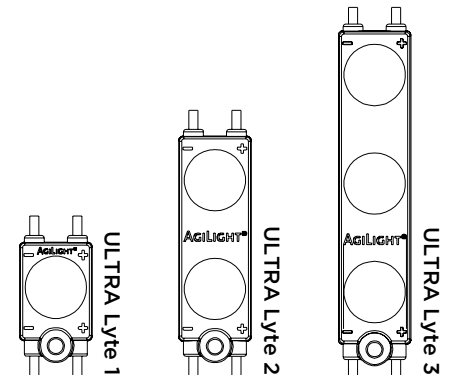

Product specifications subject to change without notice.  
REV.05APR2024

**Troubleshooting**

PROBLEM	POSSIBLE CAUSE
All LED modules are OFF or some of the LED modules are not illuminated.	1. Power supply may not be loaded properly with LED modules. 2. Wrong power supply. Must be 12VDC constant voltage. 3. Bad or loose connections.
Entire section does not light or lights intermittently.	1. Bad, loose, or improper connections. 2. Power supplies are spaced too close together; overheating. Note: Spacing between power supplies must be at least 1 inch (25.4 mm) from end to end AND 4 inches (101.6 mm) from side to side.
LED modules flicker or appear dim.	1. Power supply may not be properly loaded with LED modules. 2. Power supply may be damaged or defective. 3. Power supply may not be wired correctly. Check AC input wiring (Green to Ground, Black to Black, and White to White).

