

DMX OPTO SPLITTER

AgiLight's DMX Opto Splitter takes one DMX input signal and allows for 8 DMX output terminals. This allows you to control 8 different DMX controlled fixtures from one DMX input. Each output terminal can connect up to 32 DMX interfaces.

- DMX In/Out
- 12 VDC / 24 VDC inputs
- 8 DMX outputs
- Power In/Out
- Two-piece compression screw terminals
- IP20 Rating
- Operating Temperature: m- 10° C - 35° C



Applications:

- | | | |
|---------------|---------------|-------------|
| Commercial | Hospitality | Residential |
| Entertainment | Museums | Retail |
| Healthcare | Public Spaces | |



Dimensions

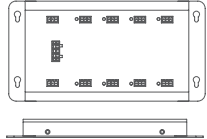

Width: 4.33 in (110 mm)
Length: 8.5 in (216 mm)
Depth: 0.82 in (21 mm)

ORDERING GUIDE

Category

DMXOS8

DMXOS8 - DMX Opto Splitter

AgiLight does not warrant or represent that the information is free from errors or omission. The information may change without notice and AgiLight is not in any way liable for the accuracy of any information printed and stored or in any way interpreted or used.

WIRING DIAGRAMS

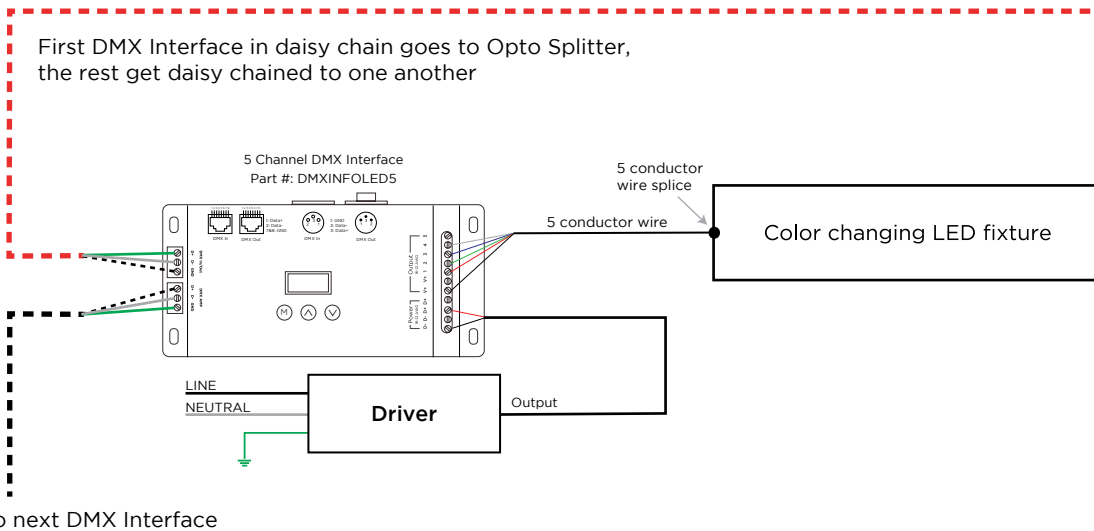
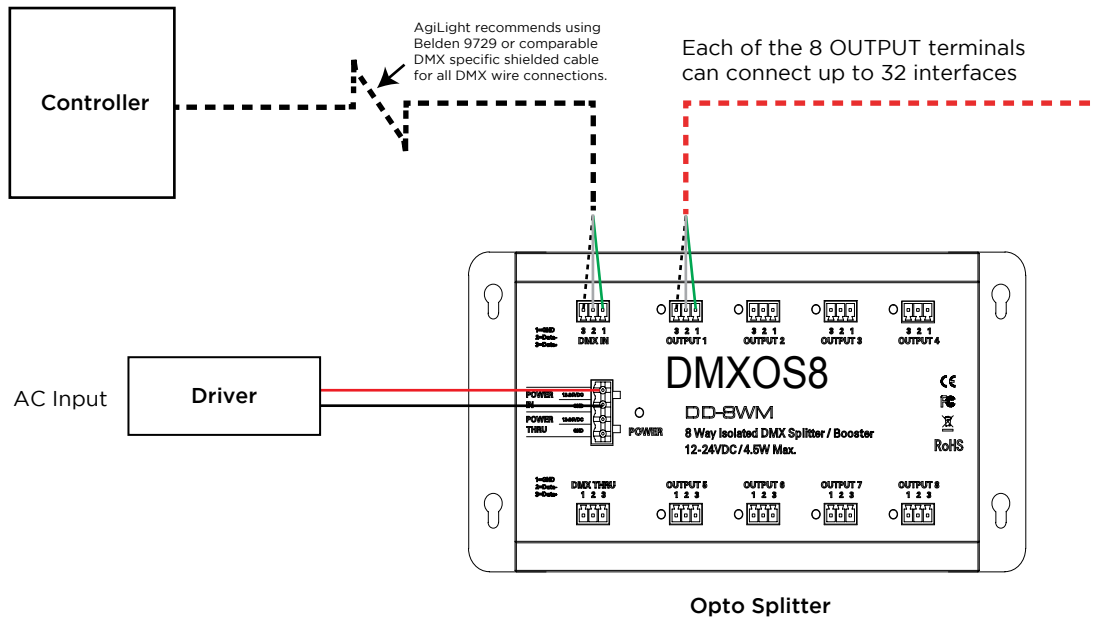

NOTE:

1. The maximum DMX Interface daisy chain is 32 before another Opto Splitter output terminal needs to be introduced.
2. The first DMX Interface in a daisy chain is wired to the Opto Splitter output. Additional DMX Interfaces can be wired to one another until the end of the daisy chain.
3. Acolyte recommends using Belden 9729 or comparable DMX specific shielded cable for all DMX wire connections.

INSTRUCTIONS:

1. Connect your controller to the Opto Splitter's **DMX In** by using data cable. Make sure the DMX+, DMX- and DMX Ground match up.
2. Connect the first DMX Interface's **DMX In** to the Opto Splitter by attaching the interface's DMX+, DMX- and DMX Ground to one of the Opto Splitter's output terminals. Make sure the DMX+, DMX- and DMX Ground match up.
3. That interface's **DMX Out** can then be connected to the next DMX Interface's **DMX In**, and so on and so forth from one to the next DMX Interface until the end of the daisy chain.
4. Connect your RibbonLyte to the DMX Interface terminals with Red wire going to the Red terminal, Green wire going to the Green terminal, Blue wire going to the Blue terminal, and, in the case of RGBW RibbonLyte, White wire going to the White terminal. Black wire is positive for RGB and RGBW RibbonLyte, so connect the Black wire to the positive (+) terminal.
5. Finally, wire the drivers (power supplies) into the Opto Splitter and each DMX Interface's positive (+) and negative (-) inputs accordingly.

AgiLight does not warrant or represent that the information is free from errors or omission. The information may change without notice and AgiLight is not in any way liable for the accuracy of any information printed and stored or in any way interpreted or used.

REV.09MAY2024